

DYNAMICROLL® FOOD PE

DESCRIPTION

DynamicRoll® **FOOD PE** is a selfrepairing roll up door studied to be used in environments, where hygiene is the most important issue. Its Polyethylene frame is designed to be sanitized in all its parts, without remove or disassemble any profiles or covers with related problems in assembling again all screws and external elements.

Columns come out from a Polyethylene monolithic section, where the zippers on curtain run inside. Thanks to the special sliding system, that lets the curtain, without rigid elements inside it, come out from the guides, to protect itself in case of any impact during the operation of the door and allows it to reinsert after one cycle.

DynamicRoll® name assures the safety of staff, thanks to its curtain without rigid horizontal elements.

ADVANTAGES

- ✓ Rapid
- ✓ Sealing
- ✓ Noiseless
- ✓ No rigid elements inside the curtain for 100% safety
- ✓ Plug & play (easy to install)
- ✓ Low maintenance
- ✓ Energy savings
- ✓ Sanitized in all parts

APPLICATION

- Door ideal for:**
- ✓ Agriculture
 - ✓ Food industry

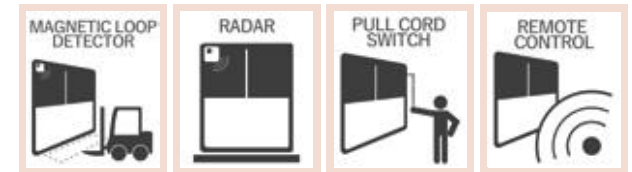

EN13241/CE

Standard	Ref.	Test acc.	Results
Water permeability	EN 12425	EN 12489	Class 1
Wind load	EN 12424	EN 12444	Class 0
Wind permeability	EN 12426	EN 12427	Class 0
Safe openings	EN 12453	EN 12445	✓
Mechanical resistance	EN 12604	EN 12605	✓
Unintended movements	EN 12604	EN 12605	✓
Thermal transmittance	EN 12428	EN 12428	6,02 W/m²K
Performance (cycles)	EN 12604	EN 12605	1.000.000

VALUES CAN CHANGE DEPENDING ON DOOR DIMENSIONS

FEATURES	
Maximum dimensions	W 4500 mm x H 3800 mm
Speed	Max opening speed up to 2 m/s
	Closing speed 0,6 m/s
Wind resistance	Class 0
Structure	Not self-supporting
Frame	Standard: Polyethylene HD 1.000.000
Motor Cover	Stainless Steel
Curtain	Standard: PVC curtain 1300 gr/m ² , 6 W/m ² K
	Optional: Insulated 7 mm, 3.3 W/m ² k Translucent 35/40% FDA (white) Antistatic
Sliding system	Patented sliding system with high density Polyethylene self- lubricant equipped of sliding zipper directly on curtain.
Control panel	Standard: PVC box IP65 (300 x 400 x 150 mm)
	Optional: Stainless Steel Powder coated steel box IP54 (300 x 500 x 150 mm)
	Inverter system 50/60 Hz with absolute encoder
	Power supply 1-ph, 230V max 16A
	Power supply 3-ph, 400V max 10A
	Power supply 3-ph, 230V max 16A
	Star/Stop Button
	2 free contacts (door open/ closed/ allarme)
	Automatic/ Manual Interlocking between 2 doors
	IP rating for motor and control panel IP54
Wiring	Plug and Play system IP65

FEATURES	
Safeties	Standard: Photocells set IP65 Anti-jam sensor reverse
	Optional: WiFi safety edge IP65
Emergency opening	Standard: Hand crank
	Optional: Chain system UPS Battery
Advising operative temperature	Operating till positive temperature (> 0° C) - Not apt to be installed in negative/positive temperature
Cycles (EN 12604)	1.000.000 (tested)

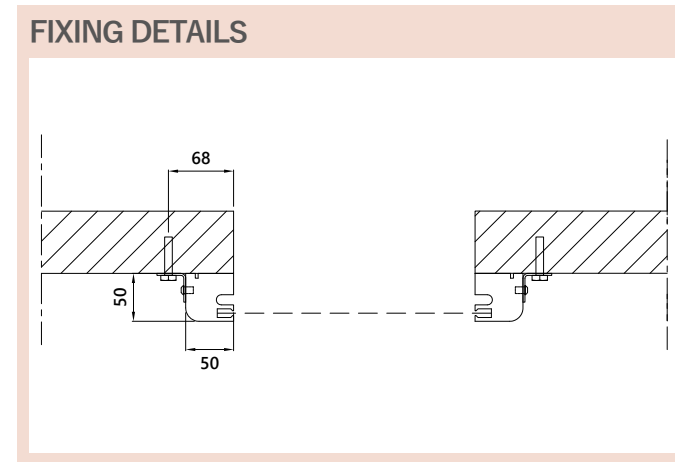
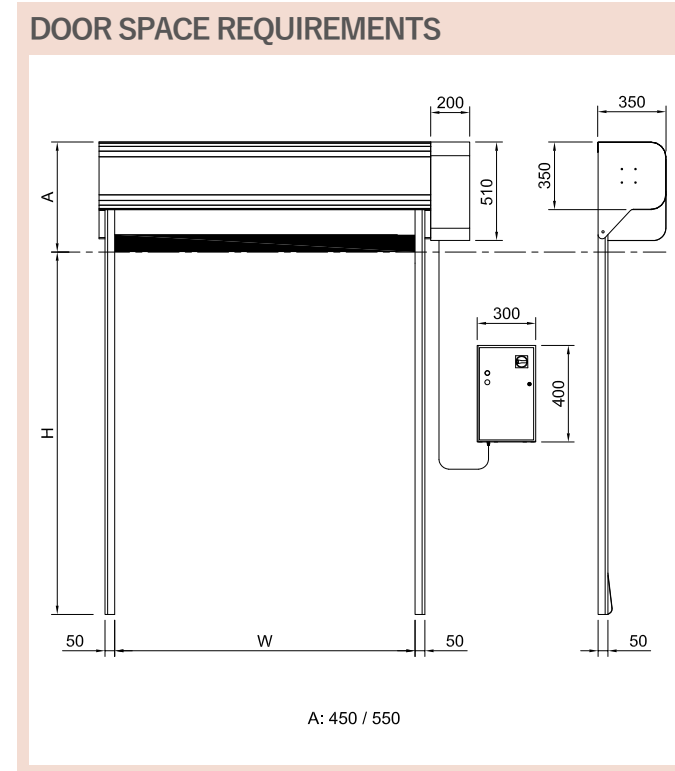
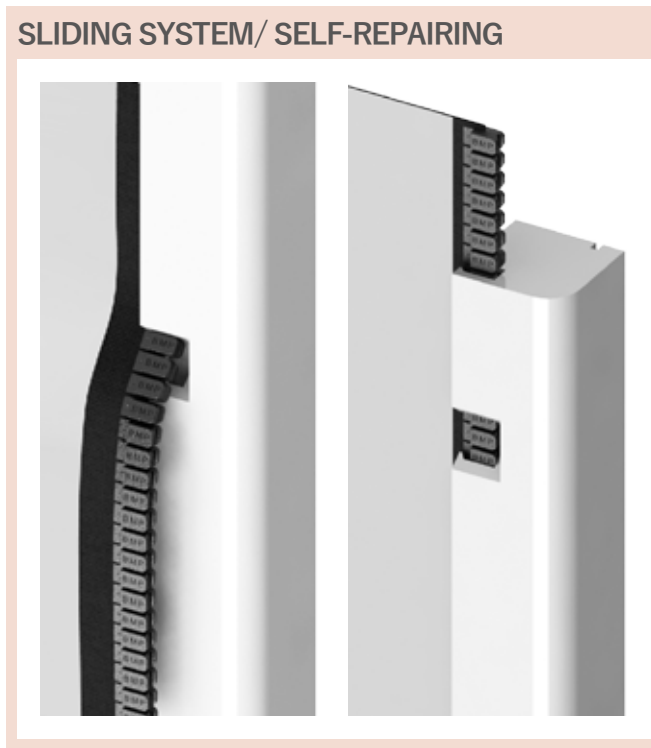

AVAILABLE COLOURS	Simil RAL 9010	Simil RAL 1015	Simil RAL 1003	Simil RAL 2004	Simil RAL 3002	Simil RAL 6026	Simil RAL 7042	Simil RAL 7037	Simil RAL 7035	Simil RAL 5012	Simil RAL 5002

*BMP Europe S.r.l. reserves the right to change the characteristics of its products or components without prior notice, depending on its policy of continuous product development. The doors shown are example applications. No part or excerpt may be reproduced without our prior permission.

