

# MEGAPACK

DESCRIPTION

**MEGAPACK** fold up door has been designed for outdoor industrial environments, where there are large openings for hangars and shipyards.

MEGAPACK industrial door guarantees long durability, energy saving and reliability with minimum maintenance.

Each industrial door is individually designed to adapt to the building on which it is to be installed and guarantees excellent wind resistance thanks to the mantle formed by two polyester fabrics connected by horizontal aluminium trusses.



EN13241/CE ADVANTAGES APPLICATION

**Fold up door with conical columns and double curtain** ideal for:

- ✓ Industry (outside)
- ✓ Shipyard
- ✓ Hangar
- ✓ Waste treatment

- ✓ Class 4 - 144 km/h
- ✓ Energy savings
- ✓ Double PVC curtains
- ✓ Minimal maintenance

Standard	Rif.	Test acc.	Results
Wind load	EN 12424	EN 12444	Class 4
Safe openings	EN 12453	EN 12445	✓
Mechanical resistance	EN 12604	EN 12605	✓
Unintended movements	EN 12604	EN 12605	✓
Performance (cycles)	EN 12604	EN 12605	1.000.000

VALUES CAN CHANGE DEPENDING ON DOOR DIMENSIONS

## FEATURES

<b>Maximum dimensions</b>	W 20.000 mm x H 15.000 mm
<b>Speed</b>	<b>Max opening speed</b> up to 0,3 m/s
	<b>Closing speed</b> 0,3 m/s
<b>Wind resistance</b>	Up to Class 4 / higher classes on a project basis
<b>Structure</b>	Not self-supporting
<b>Frame / motor cover hood</b>	<b>Standard:</b> Galvanized Steel
<b>Curtain</b>	<b>Standard:</b> PVC curtain fabric 900 gr/m <sup>2</sup>
	<b>Optional:</b> Insulated curtain PVC 1350 gr/m <sup>2</sup>
<b>Control panel</b>	<b>Standard:</b> Powder coated Steel box IP54 (400 x 500 x 2000 mm)
	<b>Optional:</b> the cabinet may be equipped with electro-mechanical system with possibility to be controlled by a PLC system
	Contactors (50 Hz)
	Power supply 3-ph, 400V
<b>Safeties</b>	Power supply 24VAC for auxiliary accessories
	<b>Standard:</b> WiFi safety edge IP65
<b>Emergency opening</b>	<b>Standard:</b> Mechanical
<b>Advising operative temperature</b>	-30° C +70° C
<b>Cycles (EN 12604)</b>	1.000.000 (tested)

## LIFTING BELTS-STRAPS

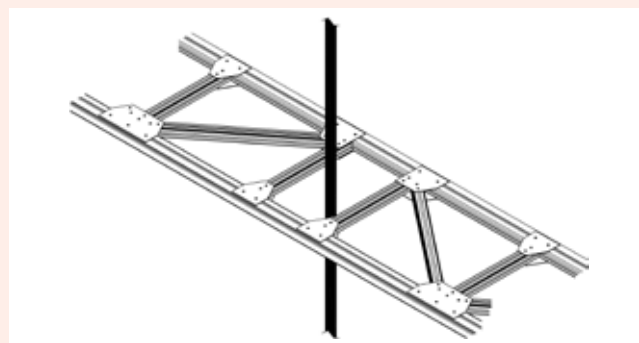

## SLIDE SLIDING COLUMNS DOOR LEAF

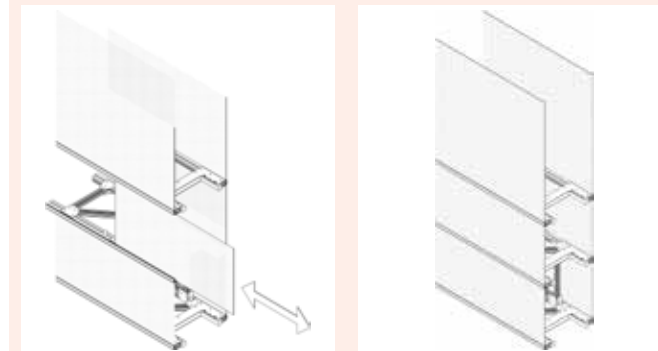

## MEGAPACK: 40 m x 18 m



## TOP HEADING

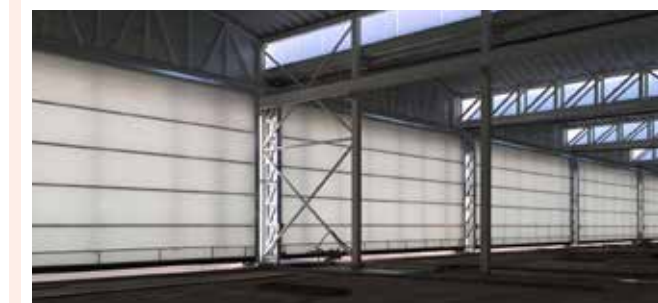
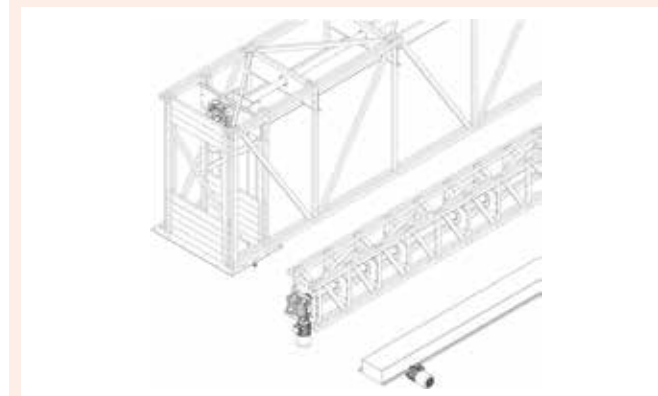

## AVAILABLE COLOURS

Simil RAL 9010

Simil RAL 1015

Simil RAL 1003

Simil RAL 2008

Simil RAL 3002

Simil RAL 6026

Simil RAL 9006

Simil RAL 7042

Simil RAL 7037

Simil RAL 7035

Simil RAL 5012

Simil RAL 5002

\*BMP Europe S.r.l. reserves the right to change the characteristics of its products or components without prior notice, depending on its policy of continuous product development. The doors shown are example applications. No part or excerpt may be reproduced without our prior permission.

