

PATENTED

GUARANTEED
1,000,000
cycles

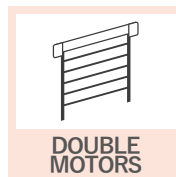
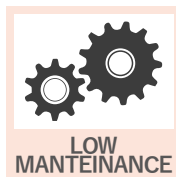

PACK

DESCRIPTION

PACK door is a fold up door composed by perimeter self-supporting frame in galvanized steel and a PVC curtain reinforced with horizontal steel bars to assure a wind resistance up to 160 Km/h. Curtain is lifted by strong belts and collected on top.

The patented conical guides give to the **PACK** a low air permeability and a good performance in case of high wind load. Studied for heavy industry too is suitable for all kind of industries. Perfect for internal and external applications, for big openings and designed for a long life.

PACK is the right solution in case of strong wind and depressions.

ADVANTAGES

- ✓ Wind resistance up to 160 km/h
- ✓ Working in depression/ pressure up to 120 km/h
- ✓ Basic automation

APPLICATION

Fold up door with conical columns and double motors ideal for:

- ✓ Waste treatment
- ✓ Airport
- ✓ Industry
- ✓ Heavy industry
- ✓ Crane door
- ✓ Chemical
- ✓ Shipyard
- ✓ Agriculture

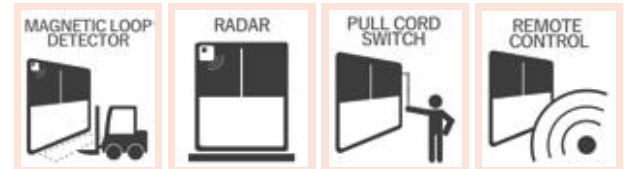

EN13241/CE

Standard	Rif.	Test acc.	Results
Water permeability	EN 12425	EN 12489	Class 1
Wind load	EN 12424	EN 12444	Class 4
Wind permeability	EN 12426	EN 12427	Class 0
Safe openings	EN 12453	EN 12445	✓
Mechanical resistance	EN 12604	EN 12605	✓
Unintended movements	EN 12604	EN 12605	✓
Thermal transmittance	EN 12428	EN 12428	6,02 W/m ² K
Performance (cycles)	EN 12604	EN 12605	1.000.000

VALUES CAN CHANGE DEPENDING ON DOOR DIMENSIONS

FEATURES	
Maximum dimensions	W 20.000 mm x H 15.000 mm
Speed	Max opening speed up to 1 m/s
	Closing speed 1 m/s
Wind resistance	Standard Class 2 up to 35 m ² further on project till Class 4
Structure	Self-supporting
Frame / motor cover hood	Standard: Galvanized Steel
	Optional: Powder coated Steel Stainless Steel 441/304/316
Telo	Standard: PVC curtain fabric 900 gr/m ²
	Optional: Insulated 3 mm Insulated 7 mm Translucent 35/40% FDA (white) Antistatic
	Standard: Powder coated Steel box IP54 (300 x 500 x 150 mm)
	Optional: Stainless Steel PVC box IP65 (300 x 400 x 150 mm)
Control panel	Contactors
	Thermail modular protection
	Power supply 3-ph, 3-230V
	Power supply 3-ph, 3-400V
	Star/Stop Button
	Emergency stop button
	IP rating for motor and control panel IP54
Safeties	Standard: Photocells set IP65 WiFi safety edge IP65
	Optional: Multi ray light curtain barrier H2500 IP67
Emergency opening	Standard: Hand crank
	Optional: Counterweight system Chain system

FEATURES	
Advising operative temperature	Operating till - 30 C° + 70° C - Not apt to be installed in negative/positive temperature
Cycles (EN 12604)	1.000.000 (tested)

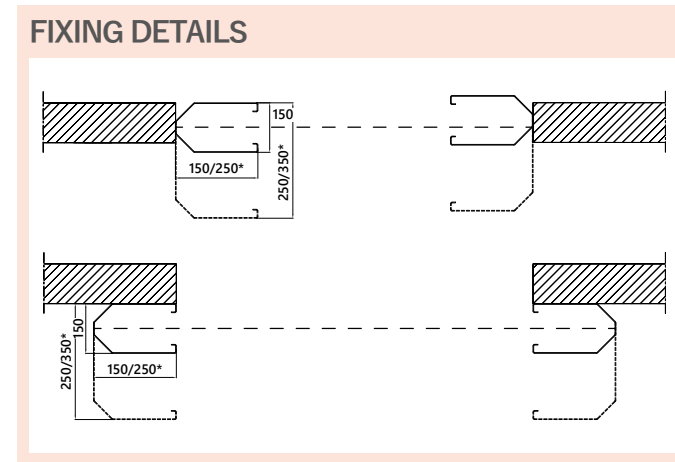
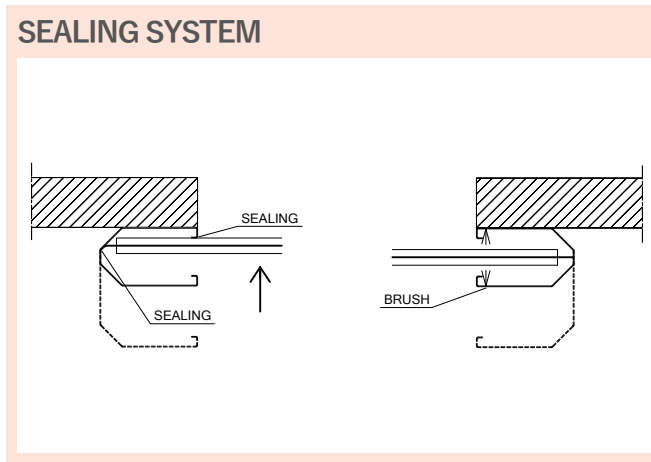
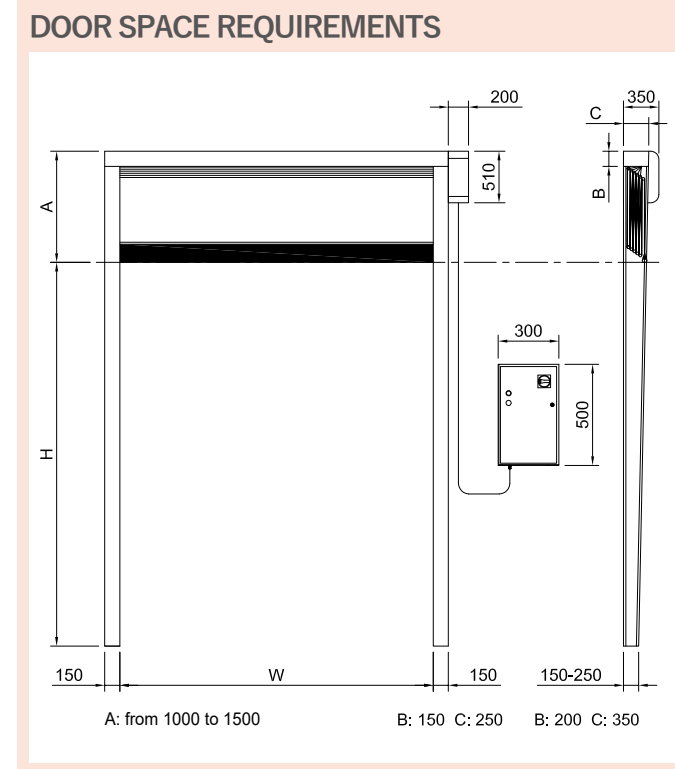

AVAILABLE COLOURS	Simil RAL 1015	Simil RAL 3002	Simil RAL 9006	Simil RAL 7035	Simil RAL 5010
Simil RAL 1003	Simil RAL 8014	Simil RAL 7042	Simil RAL 6018	Simil RAL 5002	Simil RAL 5012
Simil RAL 9010	Simil RAL 2004	Simil RAL 9005	Simil RAL 7037	Simil RAL 6026	

*BMP Europe S.r.l. reserves the right to change the characteristics of its products or components without prior notice, depending on its policy of continuous product development. The doors shown are example applications. No part or excerpt may be reproduced without our prior permission.

